

**STATE OF CALIFORNIA
DEPARTMENT OF CONSUMER AFFAIRS
BUREAU OF HOME FURNISHINGS AND THERMAL INSULATION
3485 ORANGE GROVE AVENUE
NORTH HIGHLANDS, CALIFORNIA 95660-5595**

TECHNICAL BULLETIN 133

**Flammability Test Procedure for Seating
Furniture for Use in Public Occupancies**

JANUARY 1991

TECHNICAL BULLETIN 133

Flammability Test Procedure for Seating Furniture for Use in Public Occupancies

I. Scope

- A. This test procedure is designed to test seating furniture for use in occupancies that are identified as or considered to be public occupancies. Such facilities might include, but are not limited to, jails, prisons, nursing care homes, health care facilities, public auditoriums, hotels and motels.
- B. This test procedure is not intended to be used for the evaluation of residential furniture.
- C. It is the intent of the Bureau that furniture complying with Technical Bulletin 133 be safer furniture when subjected to the ignition source specified by this test. This type of ignition may be typical of arson or incendiary fires or common accidental fires in public buildings. This Bureau expects manufacturers attempting to comply with this standard will also seek to make safer furniture, and will not attempt to compromise the intent of the standard in any manner.

II. Test Facility

- A. The test burn room shall be 12 x 10 feet or a close approximation with an 8-foot ceiling height. The room shall have no openings other than a doorway opening approximately 38 x 81 inches, located as indicated in Figures 1 and 2, and such other small openings that may be necessary to make test measurements. The test room shall be constructed of wooden or metal studs and lined with fire rated gypsum wallboard. Tests may be conducted in rooms of different physical dimensions than those specified, for example, the proposed ASTM room, when equivalent test results can be demonstrated. In addition, if compliance is claimed using the heat release criteria, tests performed using a furniture calorimeter are acceptable. When using test rooms of different dimensions or a furniture calorimeter the ignition source must be as specified in Section V of this standard.
- B. The test burn room shall be instrumented to monitor temperature, carbon monoxide concentration, smoke opacity and sample weight loss. Other test room instrumentation may be added as required. In addition, the test facility may be instrumented to measure total heat release and heat release rate when compliance with the alternate heat release criteria is claimed. A typical system used to measure heat release, on the principle of oxygen consumption, is described in Appendix A.
- C. The test room shall be unfurnished except for the test sample. The test sample shall be positioned as indicated in Figure 1 or 2.

III. Test Sample

The test sample shall consist of typical seating furniture suitable for use in public occupancies, or a full-scale mock-up of the furniture. When a full-scale furniture mock-up is used, the mock-up shall in all respects (including fabrics, filling materials, combustible decorative parts and furniture style) reflect the construction of the actual furniture that it is intended to represent. See Appendix D.

IV. Test Conditioning

The test sample and newsprint shall be conditioned for at least 48 hours prior to testing at $70\pm 5^{\circ}\text{F}$ and a relative humidity of less than 55%. Test materials shall be tested within 10 minutes of removal from such conditions if test room conditions differ from the above.

V. Test Ignition Source

- A. The test ignition source shall be a square gas burner as described in Appendix C.
- B. An ignition source of five double sheets of loosely wadded newsprint contained in an ignition box, as described in Appendix B, may be used as a screening test.

VI. Test Procedure

- A. Position thermocouple in two test locations (see Figure 1 or 2):
 - 1. Over the geometric center of the ignition source, one inch below the ceiling. This shall be designated as the ceiling thermocouple.
 - 2. Three feet in front of the ignition source, four feet below the ceiling. This shall be designated as the 4 foot thermocouple.
- B. Position a smoke opacity monitor in one test location (see Figure 1 or 2): Four feet above the floor level. This shall be designated as the 4-foot smoke opacity monitor.
- C. The gas sampling line shall be positioned 6.5 inches below the ceiling and 6.5 inches from the corner (see Figure 1 or 2).
- D. A weighing platform shall support the base of the furniture 5 ± 2 inches above the floor. The furniture and weighing platform shall be positioned in the corner so that the furniture is no more than 10 inches from both walls. If the seating furniture is no more than 40 inches in width, refer to Figure 1. If the seating furniture is more than 40 inches, refer to Figure 2.
- E. If the seating furniture is no more than 40 inches in width, the square gas burner shall be positioned at the center of the crevice area, 2 inches from the furniture back and 1 inch above the seat surface. (See Figures 12D and 13).
- F. If the seating furniture is more than 40 inches in width, the square gas burner shall be positioned 5 inches from the left arm crevice or edge of the seating surface. (See Figures 12D and 14).

- G. The gas flow through the square gas burner, described in Appendix C, shall be maintained for 80 ± 2 seconds.
- H. Allow combustion to continue until:
 - 1. All combustion has ceased; or
 - 2. 1.0 hour of testing has elapsed; or
 - 3. Flameover or flashover appears to be inevitable.

VII. Test Criteria

- A. Seating furniture fails to meet the requirements of this test procedure if any of the following criteria are exceeded in a room test using the room instrumentation.
 - 1. A temperature increase of 200°F or greater at the ceiling thermocouple.
 - 2. A temperature increase of 50°F or greater at the 4-foot thermocouple.
 - 3. Greater than 75% opacity at the 4-foot smoke opacity monitor.
 - 4. Carbon monoxide concentration in the room, as measured in accordance with Section VI, Part C, of 1000 ppm or greater for 5 minutes.
 - 5. Weight loss due to combustion of 3 pounds or greater in the first 10 minutes of the test.
- B. Seating furniture fails to meet the requirements of this test procedure if any of the following criteria are exceeded in a room test using oxygen consumption calorimetry.
 - 1. A maximum rate of heat release of 80 kW or greater.
 - 2. A total heat release of 25 MJ or greater in the first 10 minutes of the test.
 - 3. Greater than 75% opacity at the 4-foot smoke opacity monitor.
 - 4. Carbon monoxide concentration in the room, as measured in accordance with Section VI, Part C, of 1000 ppm or greater for 5 minutes.

Note

It is not required that all of the above criteria in VII A and VII B, be measured. Furniture must comply with the criteria described in VII A or VII B. When a furniture calorimeter is used furniture must comply with Criteria B, 1 and 2.

VII. Caution

Full-scale fire tests may be dangerous. All tests should be supervised by experienced test personnel. Adequate fire suppression equipment and self-contained breathing devices must be available for test personnel. Products of combustion can be irritating and dangerous; therefore, test personnel must avoid exposure to smoke and gases produced during testing as much as possible. Full-scale fire tests should never be left unattended. Test personnel must be certain upon completion of the test that combustion is totally suppressed. The performance of the submitted sample is not necessarily an accurate indication of the performance of the furniture in a real-life fire situation.

APPENDIX A

Calculation of the Rate of Heat release by the Method of Oxygen Consumption

This appendix describes the method of measurement of rate of heat release from burning furniture based on the principle of oxygen depletion. Part I describes the instrumentation required for flow and oxygen depletion measurements. Part II describes the method of, and equations for the calculation of rate of heat release.

PART I INSTRUMENTATION

The following is a description of the gas sampling technique and instrumentation used by the Bureau of Home Furnishings to determine the rate of heat release - based on oxygen depletion. Alternative techniques and/or equipment that provide accurate determination of oxygen depletion and the rate of heat release are acceptable.

A. Collection of Combustion Gases and Flow Measurement

A suitable sized collection hood should be installed at the top of the doorway entrance. The hood should be designed and located to ensure a well mixed sample of gases for analysis. The path of the exhaust duct should be at least 20 feet long to ensure accurate flow velocity measurements and may have turning and straightening vanes installed as shown in Figures 9a, 9b and 9c.

B. Duct Air Velocity Measurement

A bi-directional probe or an equivalent system shall be used to measure gas velocity in the duct. The bi-directional probe shall be mounted at the center line of the duct parallel to the direction of the air flow. A pressure transducer with a range of 0 to 1 torr, or equivalent, shall be used to measure the pressure differential across the bi-directional probe in the duct. A thermocouple shall be installed next to the bi-directional probe to record the temperature of the flowing gases. This temperature along with the pressure differential is required to calculate the velocity of the flow in the exhaust duct.

C. Gas Sampling Probe in the Duct

In order to determine oxygen depletion due to the combustion of burning articles, a sample of the exhaust gases shall be extracted from the exhaust duct to measure the mole fractions of oxygen, carbon monoxide and carbon dioxide. A stainless steel gas sampling tube shall be used to obtain a continuously flowing sample. The location and configuration of the sampling probe shall ensure collection of a representative sample of well mixed gases. A suitable sampling tube is shown in Figures 10a-d. Alternative designs that allow an integral sampling of gases over the cross-section of the exhaust duct are acceptable.

PART II EQUATIONS

A. The rate of heat production shall be calculated as follows:

$$\dot{Q} = E' X_{O_2}^{\circ} V_A \left[f - \left(\frac{E'' - E'}{E'} \right) \left(\frac{1 - f}{2} \right) \frac{X_{CO}}{X_{O_2}} \right] \quad (1)$$

where:

E' = net heat of combustion per unit volume of oxygen consumed, 17.2 MJ/m³,

E'' = heat release per unit volume of oxygen consumed in the burning of CO, 23.1 MJ/m³ referred to 25°C.

V_A = the volume flow rate of air into the system corrected to 25°C (including that which enters the room and that which passes directly into the exhaust duct)

X_i = mole fraction of the gas specie i, in the gas analyzer,

X_i° = mole fraction of the gas specie i, entering the system, in the gas analyzer, i.e., the initial mole fractions,

ϕ = oxygen depletion.

B. The oxygen depletion or the fraction of oxygen consumed is as follows:

$$f = \frac{X_{O_2}^{\circ} - \frac{X_{O_2}^{\circ} (1 - X_{CO_2}^{\circ})}{(1 - X_{CO_2}^{\circ} - X_{CO}^{\circ})}}{X_{O_2}^{\circ} \left(1 - \frac{X_{O_2}^{\circ}}{(1 - X_{CO_2}^{\circ} - X_{CO}^{\circ})} \right)} \quad (2)$$

C. The volume flow rate in the exhaust duct is given by,

$$V_s = 1 - fV_A + \alpha fV_A \quad (3)$$

Where V_s and V_A are referred to standard conditions (25°C and 1 atm) and α is the expansion factor of the air that is depleted of its oxygen. So

$$V_A = \frac{V_s}{(1 + (\alpha - 1)f)} \quad (4)$$

The value of α ranges from 1.0 for carbon to 1.175 for cellulose with plastics having values in between. In order to reduce the error incurred when unknown

products are burning, α is taken to have an intermediate value of 1.084 which is exact for propane, the calibration burner gas. Setting $\alpha=1.084$, $E'=17.2 \text{ MJ/m}^3$ and $E''=23.1 \text{ MJ/m}^3$, equation (1) becomes:

$$\dot{Q} = 17.2 X_{O_2}^\circ \frac{V_s}{(1+0.084f)} \left[f - 0.3429 \left(\frac{1-f}{2} \right) \frac{X_{CO}}{X_{O_2}} \right] \text{ MW} \quad (5)$$

where V_s is measured in the exhaust duct as cubic meters per second.

- D. If the gas velocity in the exhaust duct is measured with a pitot-static tube or a bi-directional probe, the standard volume flow rate is given by:

$$V_s = jkA \left[\frac{2\Delta P T_s}{\rho_0 T_0} \right]^{1/2} = 0.07536 jkA [\Delta P T_s]^{1/2} \text{ m}^3/\text{sec} \quad (6)$$

where T_s is the gas temperature in the duct in degrees K and ΔP is the pressure differential across the bi-directional probe (or pitot-static tube) in Pa, A is the cross-sectional area of the duct in m^2 , k is the ratio of the average mass flow rate per unit area to the centerline mass flow rate per unit area, j is a calibration factor equal to unity for a pitot-static tube and 0.926 for a bi-directional probe, and ρ_0 is the density of air, kg/m^3 , at the reference temperature T_0 , °K.

- E. When carbon monoxide is not measured in the sampling line or its mole fraction can be neglected compared with the mole fraction of CO_2 , the equation for the oxygen depletion can be simplified as:

$$f = \frac{X_{O_2}^\circ - \frac{X_{O_2} (1 - X_{CO_2})}{(1 - X_{CO_2})}}{X_{O_2}^\circ \left(1 - \frac{X_{O_2}}{(1 - X_{CO_2})} \right)} \quad (7)$$

and the rate of heat release equation will be:

$$\dot{Q} = \frac{17.2 X_{O_2}^\circ V_s f}{(1+0.084f)} \text{ MW} \quad (8)$$

- F. The room and ducting shall be calibrated using a porous gas burner with a 12 by 12 inch top surface and a 6 inch depth. A gas burner may be constructed with a 1 inch thick (25 mm) plenum; or alternatively a minimum 4 inch (100 mm) layer of Ottawa sand can be used to provide the horizontal surface through which the gas is supplied. This type of burner is shown in Figure 11. The gas supply to the burner shall be of commercial grade propane and shall have a gross heat of combustion of approximately $20,000 \pm 200 \text{ Btu/lbm}$. The flow rate of propane shall

be metered and kept constant throughout the calibration test. A minimum of 2 calibration points shall be obtained. A lower heat release value of 40 kW shall be obtained which is the equivalent of approximately 1.0 standard ft³/min (28.32 lit/min) of propane. Then a higher heat release value of 169 kW shall be obtained. This is the equivalent of approximately 4.0 standard ft³/min (113.27 lit/min) of propane. Both tests shall be conducted for a period of 10 minutes.

APPENDIX B

Newsprint Ignition Source

- A. This appendix describes the newsprint ignition source which may be used for compliance or screening testing. This ignition source consists of five double sheets of loosely wadded newsprint contained in Ignition Box A, B or C as appropriate. The newsprint shall not be tightly crumpled, but should be loosely wadded to approximately fill the selected ignition box.
- B. One of three ignition boxes shall be used. Ignition Box A shall be used for furniture with a seat/back crevice. Ignition Box B shall be used with furniture that does not have a crevice. Ignition Box C shall be used for furniture that has a gap in the crevice area.
1. The following is a description of Ignition Box A:
 - a. The 10 x 10 x 10 inch ignition box shall be constructed of .016 inch thick galvanized steel flashing and one inch hexagonal chicken wire. The steel flashing shall be cut 10 x 20 inches. A 7 inch long x 1.5 inch deep notch shall be cut centrally along a 10 inch side. One-eighth inch diameter holes shall be punched along both 20 inch sides on 1 inch centers, 0.5 inches from the edge of the flashing. The flashing shall be bent to form a right angle producing two 10 x 10 inch sides of the ignition box. Two pieces of chicken wire shall be cut 11 x 11 inches. The chicken wire shall overlap one inch on the outside of the flashing. A 20 gauge wire shall be used to attach the chicken wire to the flashing through the 1/8 inch holes. The two remaining sides of the ignition box shall be left open (see Figure 3). The ignition box shall be used as indicated in Figures 4 and 5.
 - b. Before use, the ignition box should be discolored. This may be accomplished by burning several batches of crumpled newspapers inside the box.
 2. Ignition Box B shall be similar to Ignition Box A with the following changes:
 - a. Only the side in contact with the seating area shall be left open. An 11 x 12 inch piece of previously described chicken wire shall be used to cover the 10 x 10 inch rear side of the box. Overlap and attachment shall be as previously described.
 - b. The 7 inch long x 1.5 inch deep notch shall be eliminated from the top of the ignition box.
 3. Ignition Box C shall be similar to Ignition Box B with the following changes:
 - a. A 7 inch long x 1.5 inch deep notch shall be cut centrally from the top of the ignition box. The open side of the box will be in contact with the seating area and the notch will be facing the back of the chair.
- C. Each double sheet of newsprint shall have the approximate dimensions of 23 x 28 inches. Five double sheets of newsprint shall have the combined weight of 90 grams \pm 5

grams. Newsprint shall be black and white only; sheets with any type of color shall not be used.

APPENDIX C

Square Gas Burner Ignition Source

- A. This appendix describes the square gas burner ignition source which may be used for compliance or screening testing. This ignition source utilizes propane gas as fuel at a volume flow rate of approximately 13 liters per minute for a period of 80 seconds. The propane gas is the same commercial grade as described in Appendix A.
- B. The following is a description of the square gas burner:

The 250 x 250 mm (or approximately 10 x 10 inch) square burner shall be constructed of 1/2 inch OD stainless-steel tubing with 0.035 inch wall thickness (see Figure 12a). The front side shall have 14 holes pointing straight out and spaced 13 mm apart and 9 holes pointing straight down and spaced 13 mm apart. The right and left sides shall have 6 holes pointing straight out and spaced 13 mm apart and 4 holes pointing at 45° angle inward and spaced 50 mm apart. All holes shall be of 1 mm diameter (see Figures 12a-c). The 42 inch straight arm of the burner shall be welded on to the rear of the front side (Figure 12a) in a 30° angle. The burner shall be mounted on an adjustable height pole and be balanced by a counter weight or other appropriate mechanism (Figure 12d).

Note 1: When the flow of propane to the burner is stopped the burner shall be removed from the chair and away from high temperature gases. If the square gas burner is to be exposed to heat during burning of the test article, arrangements must be made to allow the remaining propane gas inside the tube to be freely released to avoid any possibility of explosion.

Note 2: Care must be taken to allow free flow of propane through the burner holes. Periodic cleaning of soot deposit and blowing pressurized air through the tube is recommended.

APPENDIX D

Furniture Mock-Up System

Technical Note

In lieu of testing finished products, full-scale mock-up testing may be performed according to the following test procedure.

- A. The test sample shall consist of component cushions which duplicate the thickness, construction and design features of a product suitable for use in public occupancies.
- B. A metal test frame (Figures 6 and 7) shall be used to support seat and back cushions and, if necessary, arm cushions. The chair frame shall be constructed of slotted "L" angle iron and slotted flat angle iron. The back shall be constructed so that it is adjustable to a maximum angle of 135° from the horizontal plane. The test frame shall be adjustable to accommodate test cushions of various thicknesses and sizes, with or without arm cushions.
- C. Component back, seat and arm cushions shall be constructed into mock-up designs of the actual article of furniture. Construction should duplicate all layers found in the actual article of furniture. Cushion construction shall consist of either:
 1. Manufacturer's prefabricated cushions of the appropriate size; or
 2. Custom-made cushions of the appropriate size. Cushions are constructed by covering the face and four edges of the filling material with the appropriate interliners, etc. and cover fabric. On the back of each cushion, a two-inch overlap of the cover fabric is stapled together and a wire is loosely woven through the fabric edges and drawn to produce a close fit (see Figure 8).
- D. The constructed seat cushion may be placed horizontally on the seat area of the test frame and pushed against the back of the frame. The constructed back cushion may then be placed vertically against the back support of the test frame. The back cushion shall be held in place by wire to prevent it from falling forward. If arm cushions are used, the constructed arm cushions may be placed between the seat cushion and the arm supports of the test frame. However, the placement of the seat, back and arm cushions should be done to most closely duplicate the design features of the completed article of furniture.
- E. The test procedure shall be the same as for completed articles of furniture (see Section VI). The test criteria shall be the same for completed articles of furniture (see Section VII).
- F. For upholstered furniture products containing only wood and/or metal frames, the above procedure appears to be an accurate indicator of the open-flame performance of the finished article. For upholstered furniture products containing

plastic frames and plastic decorative parts, this procedure may not be an accurate indicator of the open-flame performance of the finished article unless the plastic parts are included in the mock-up tested.

FIGURE 1

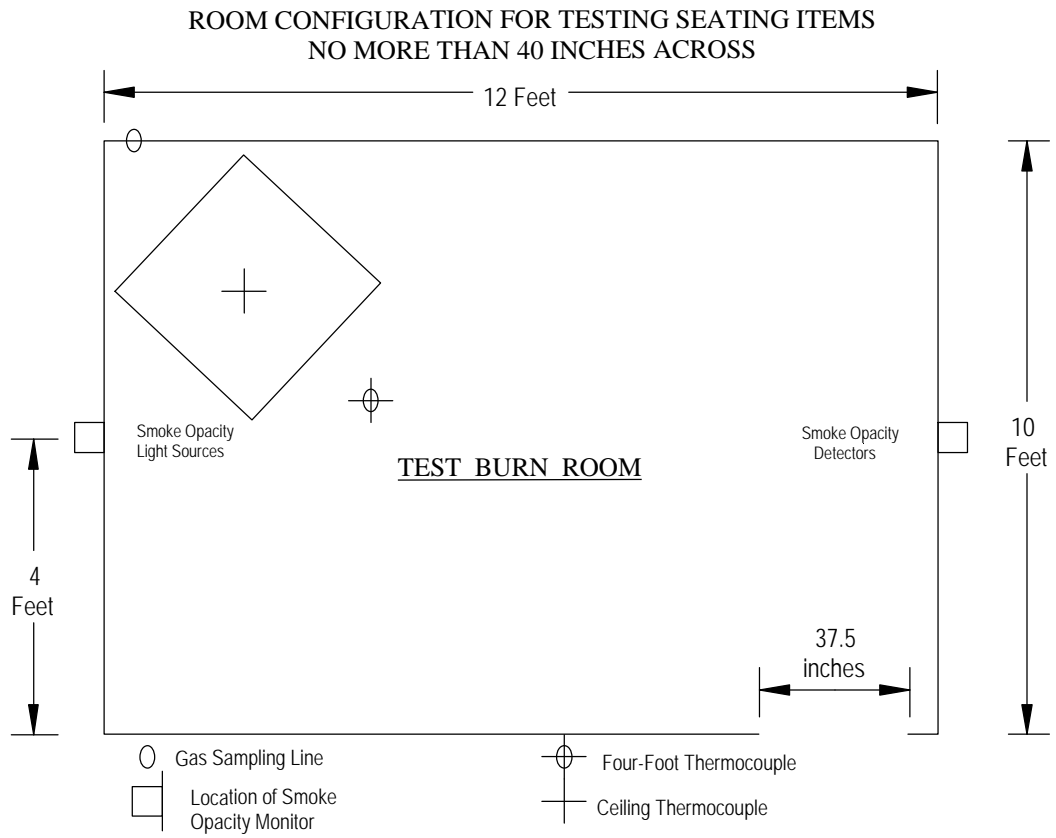

FIGURE 2

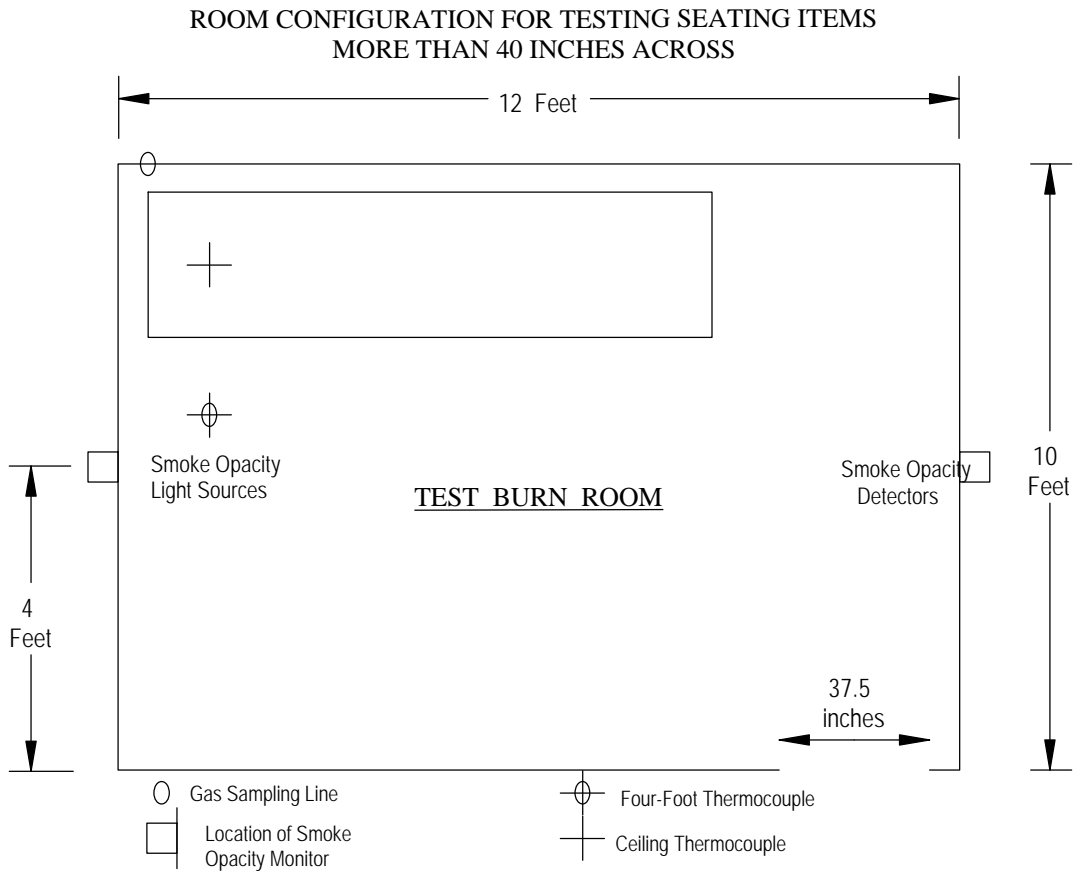

FIGURE 3
IGNITION BOX A

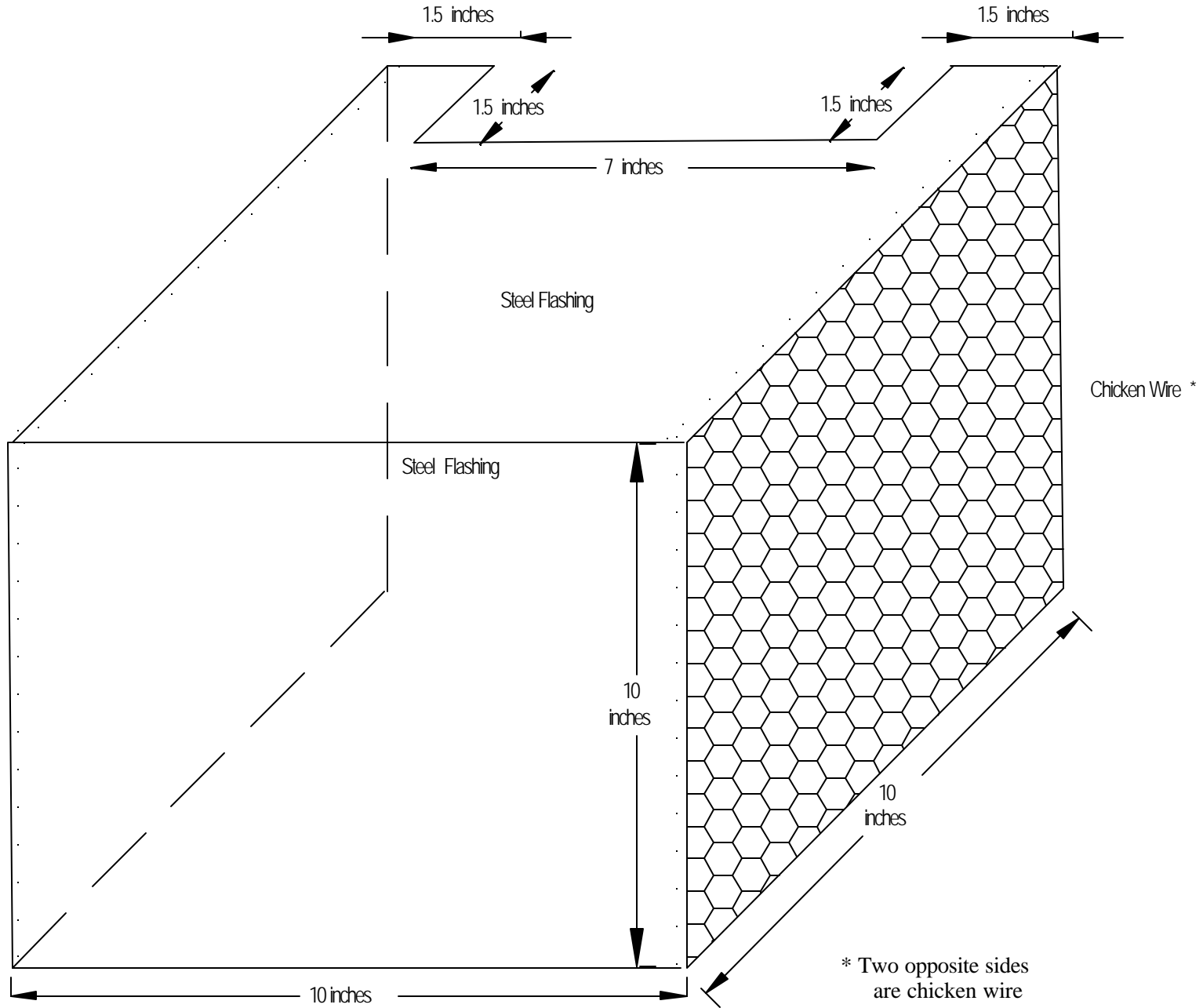

FIGURE 4

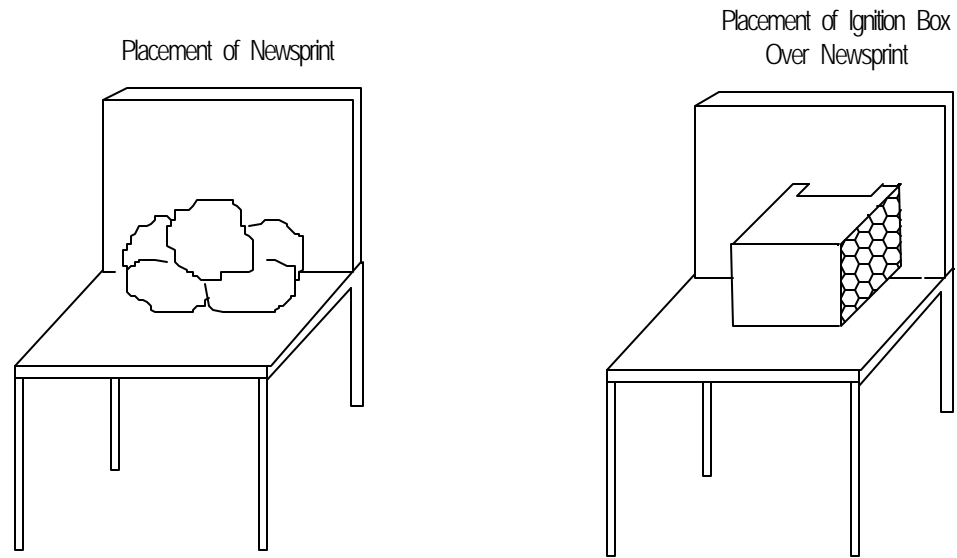

FIGURE 5

Placement of Ignition Box
Seating items more than 40 inches across

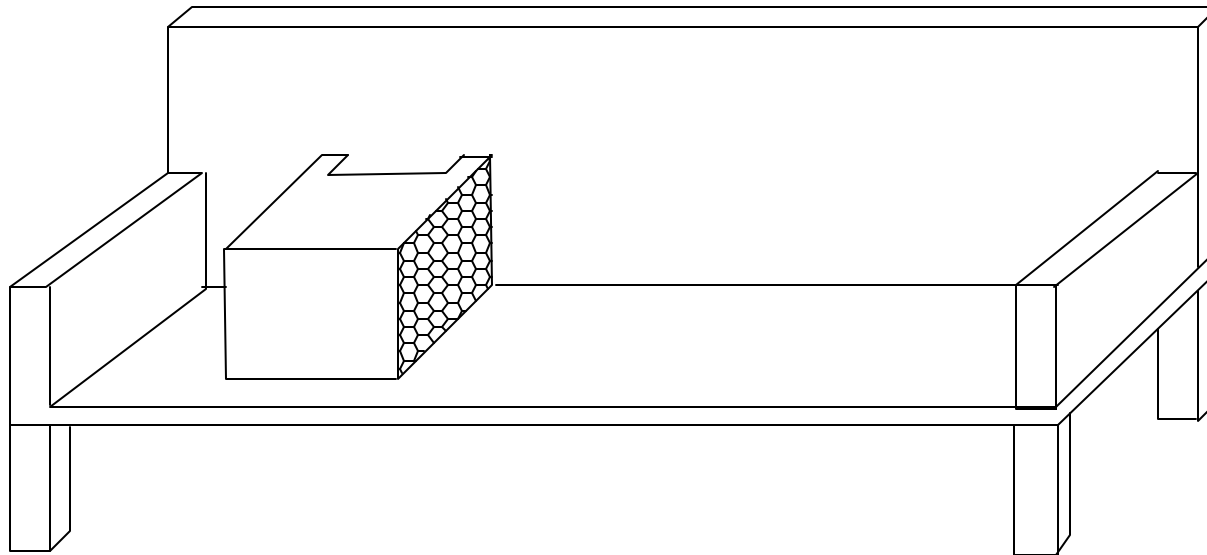

FIGURE 6
METAL TEST FRAME

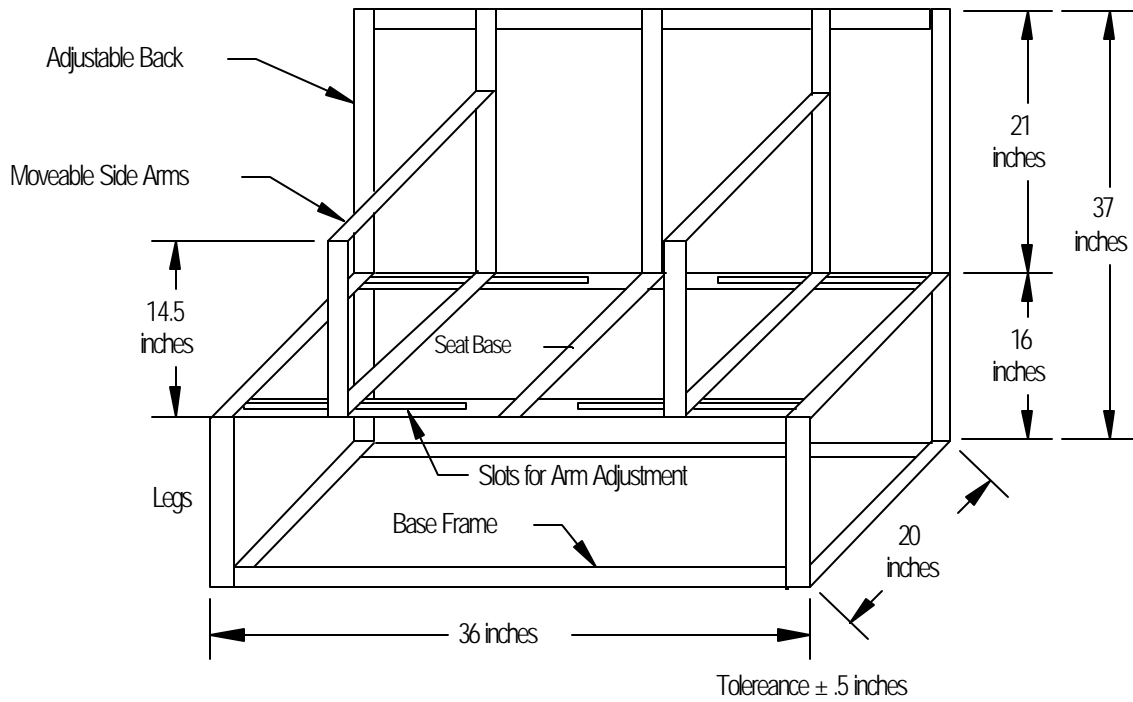

FIGURE 7
METAL TEST FRAME
(END VIEW)

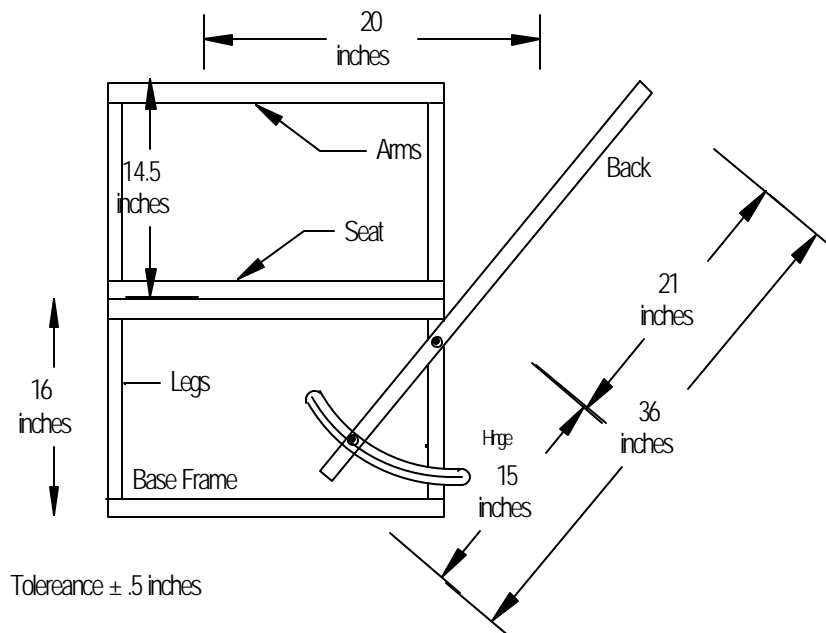
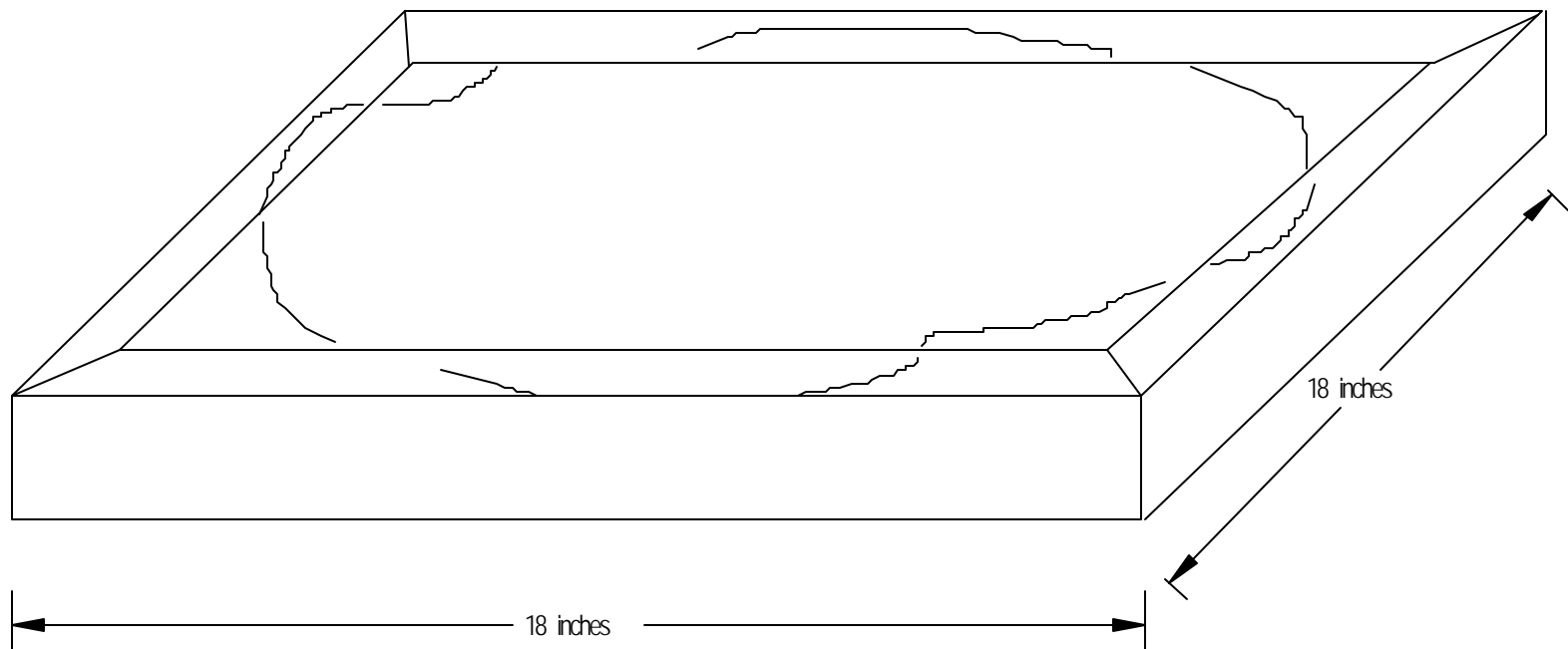
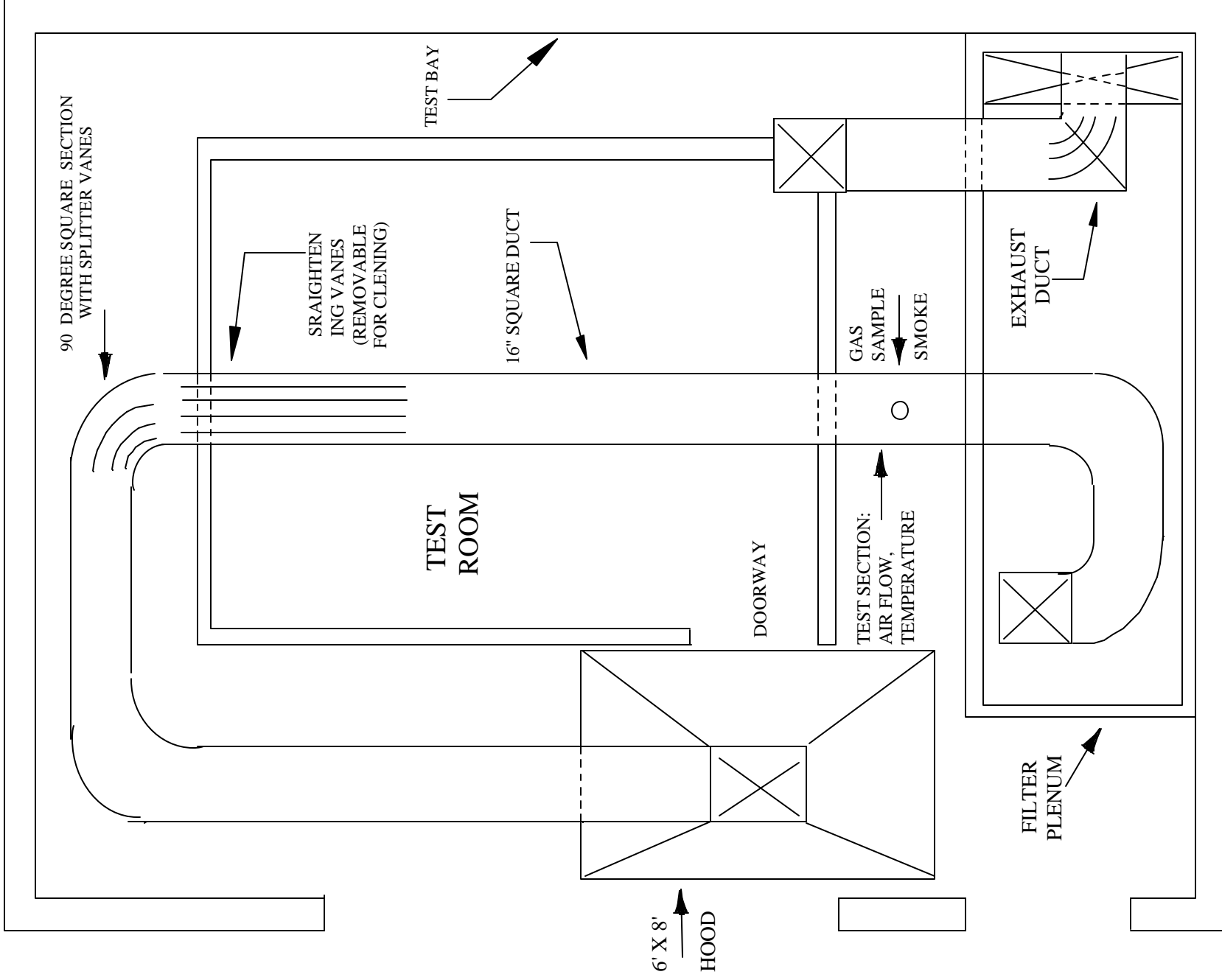

FIGURE 8
BACK VIEW OF CONSTRUCTED CUSHION



Tolerance ± 1 inch



PLAN VIEW OF THE TEST ROOM AND EXHAUST DUCT
 FIGURE 9a

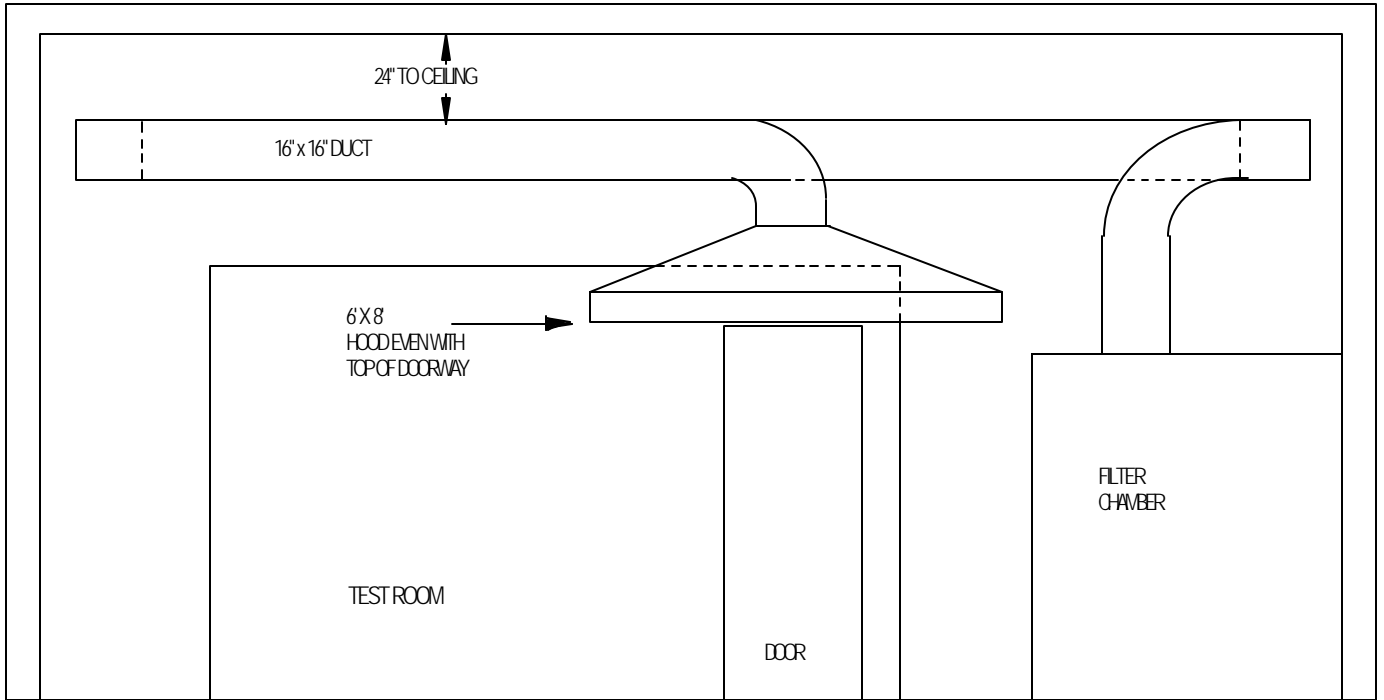

FRONT VIEW OF THE TEST ROOM AND THE EXHAUST DUCT
FIGURE 9b

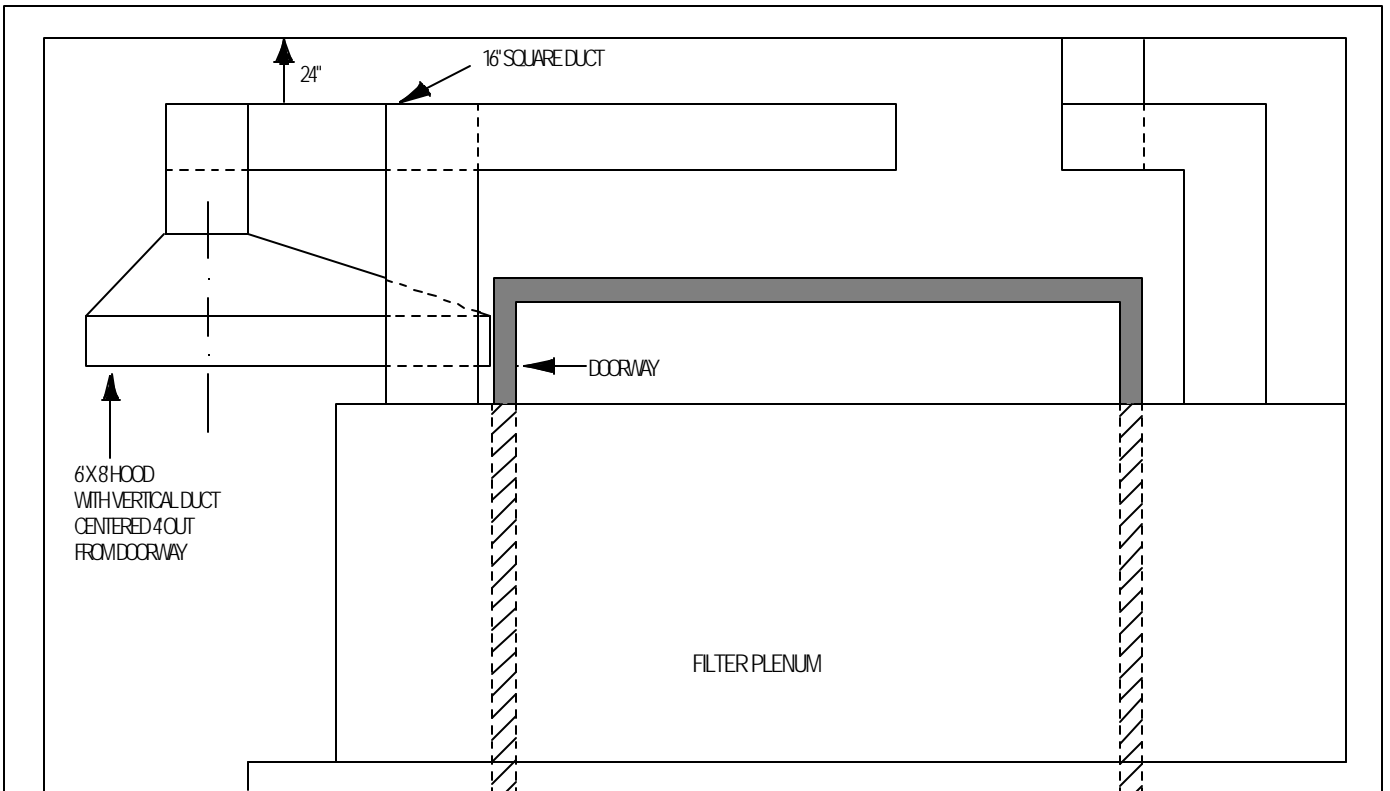

SIDE VIEW OF THE TEST ROOM AND THE EXHAUST DUCT
FIGURE 9c

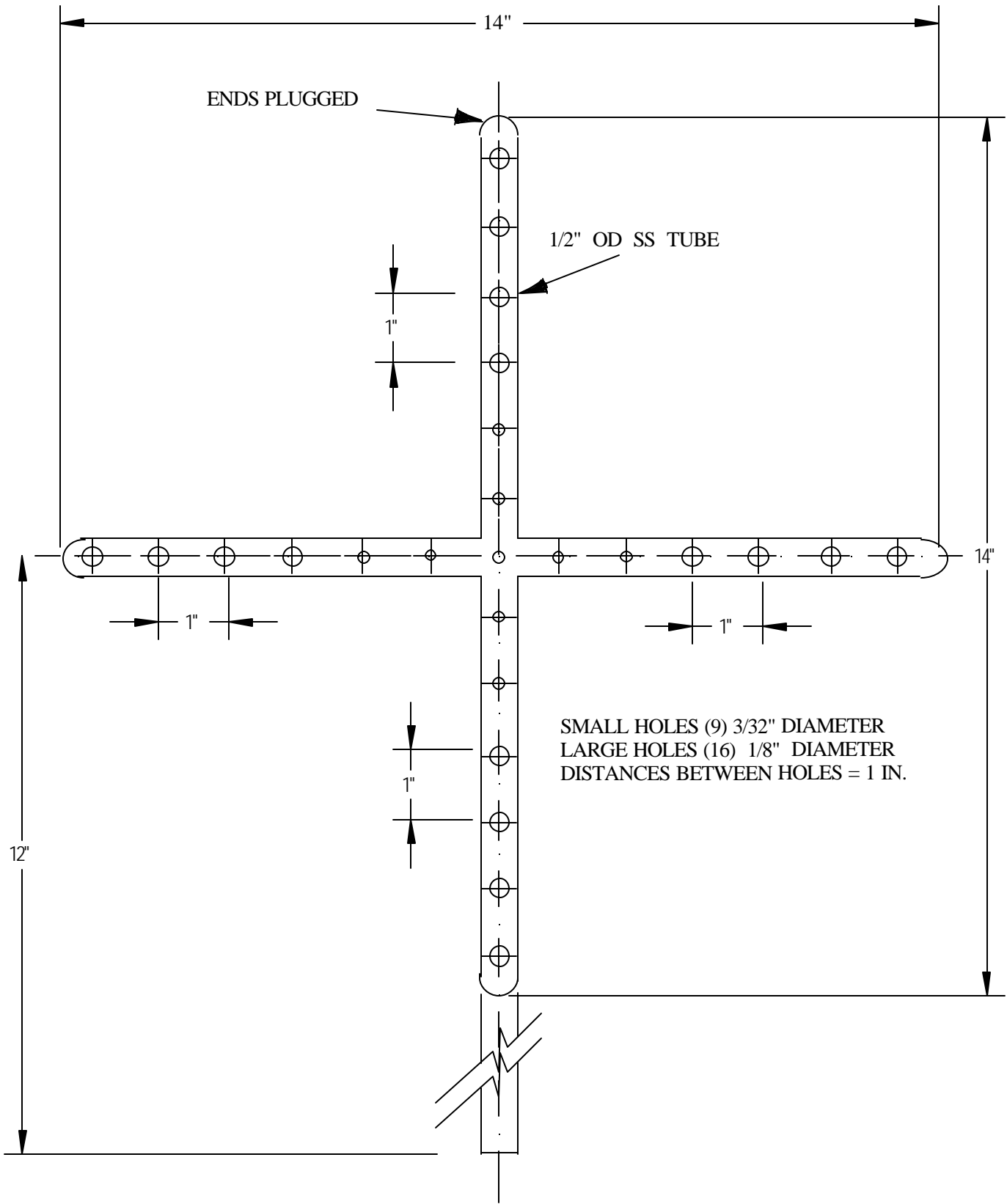

FRONT VIEW OF GAS SAMPLING PROBE
 FIGURE 10a

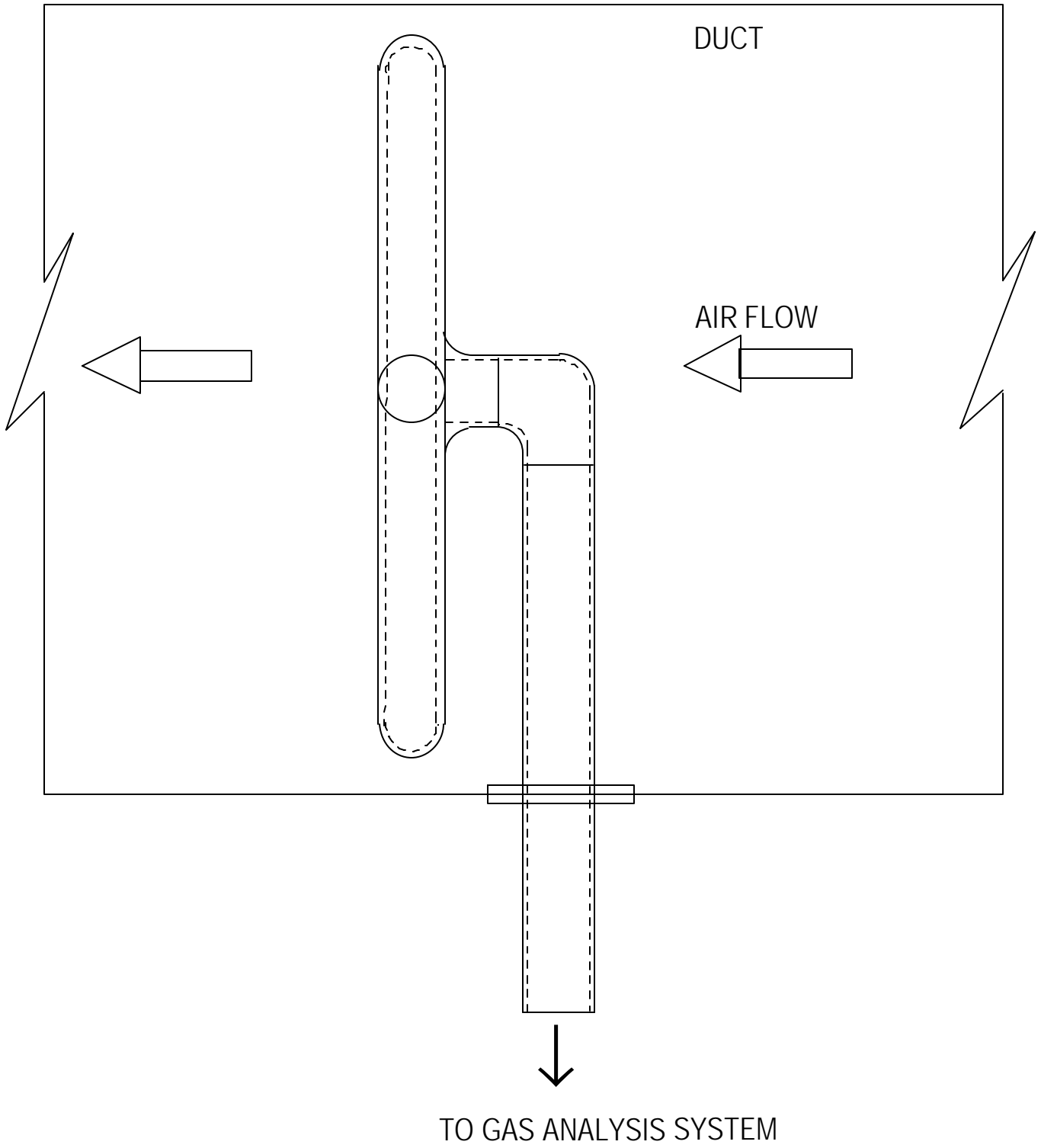

SIDE VIEW OF THE GAS SAMPLING PROBE IN THE DUCT
FIGURE 10b

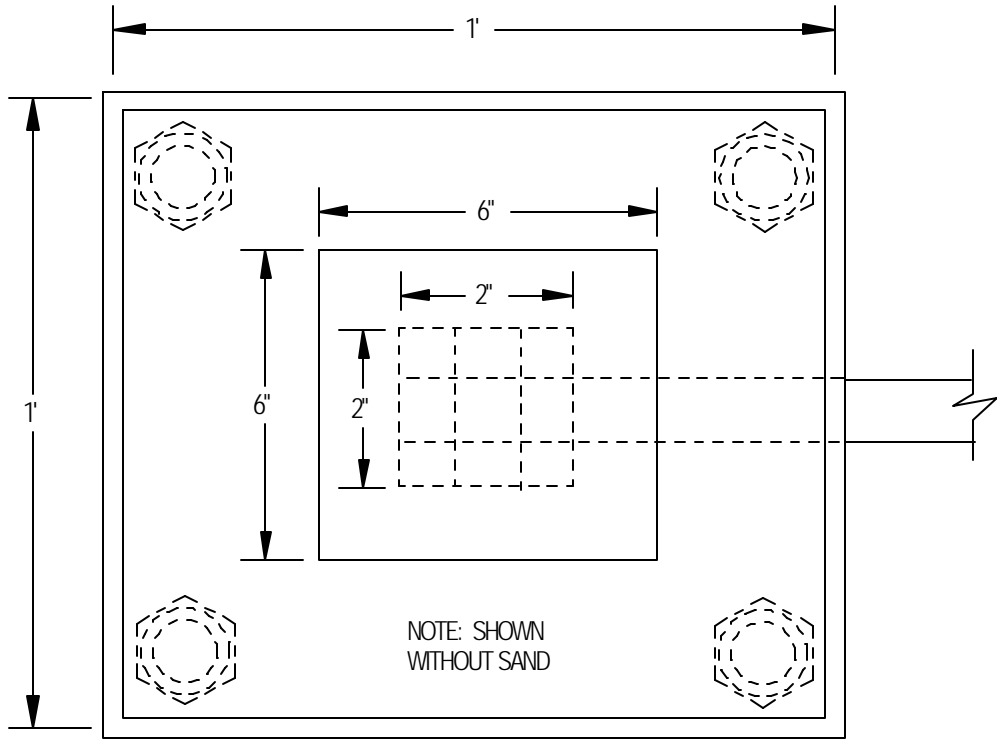

PLAN VIEW

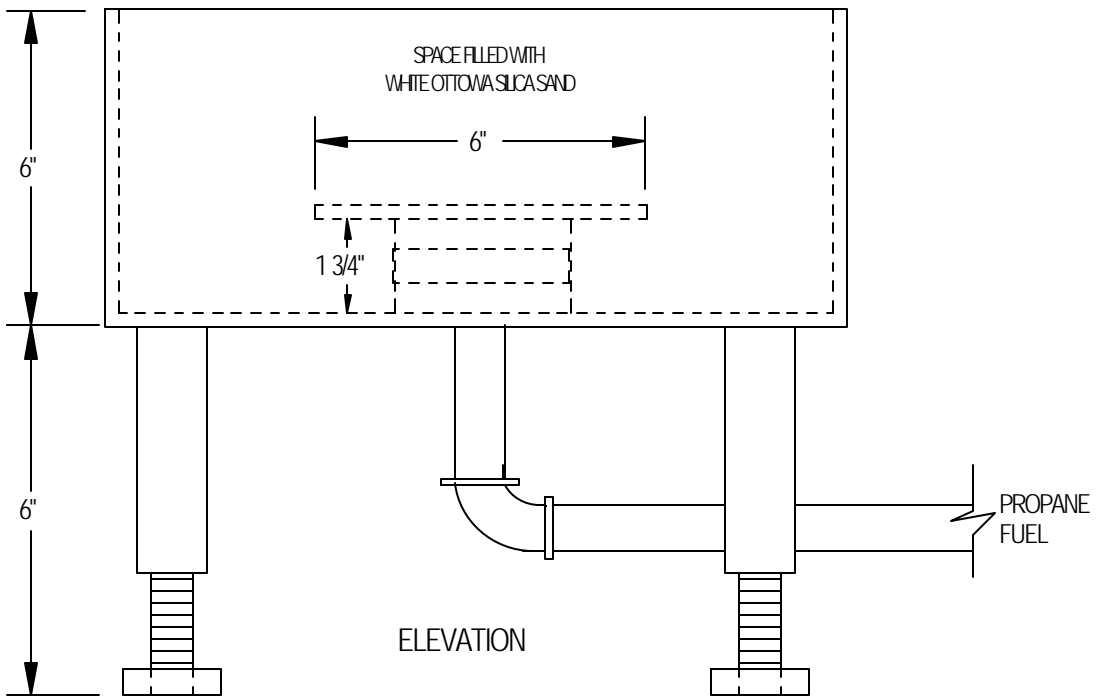

ELEVATION

CALIBRATION GAS BURNER
FIGURE 11

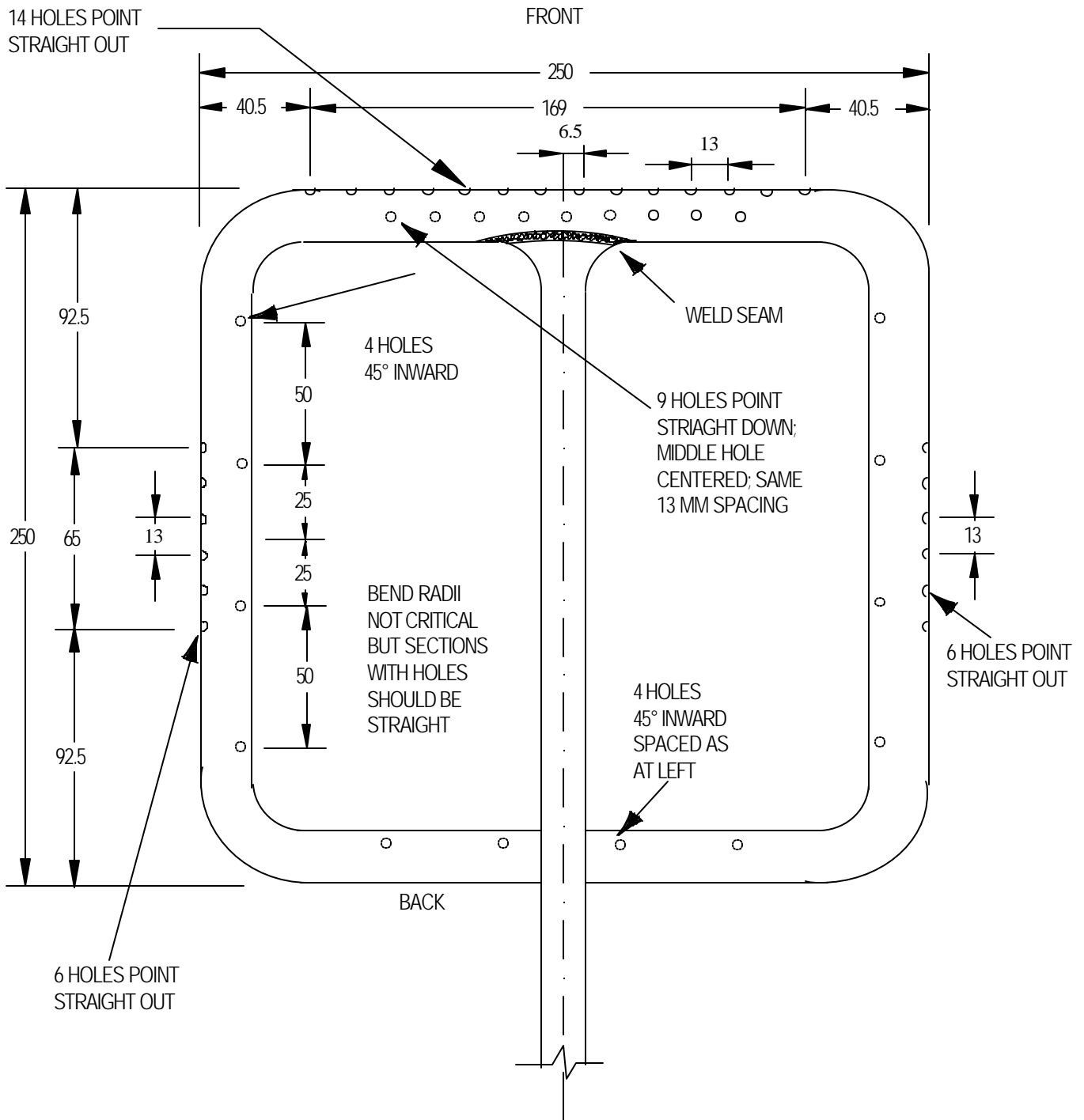

- NOTE: 1. All tubing 1/2" OD, SS, 0.035" wall thickness.
 2. All holes 1 mm in diameter.
 3. All units are mm unless otherwise noted.

PLAN VIEW OF SQUARE GAS BURNER
 FIGURE 12a

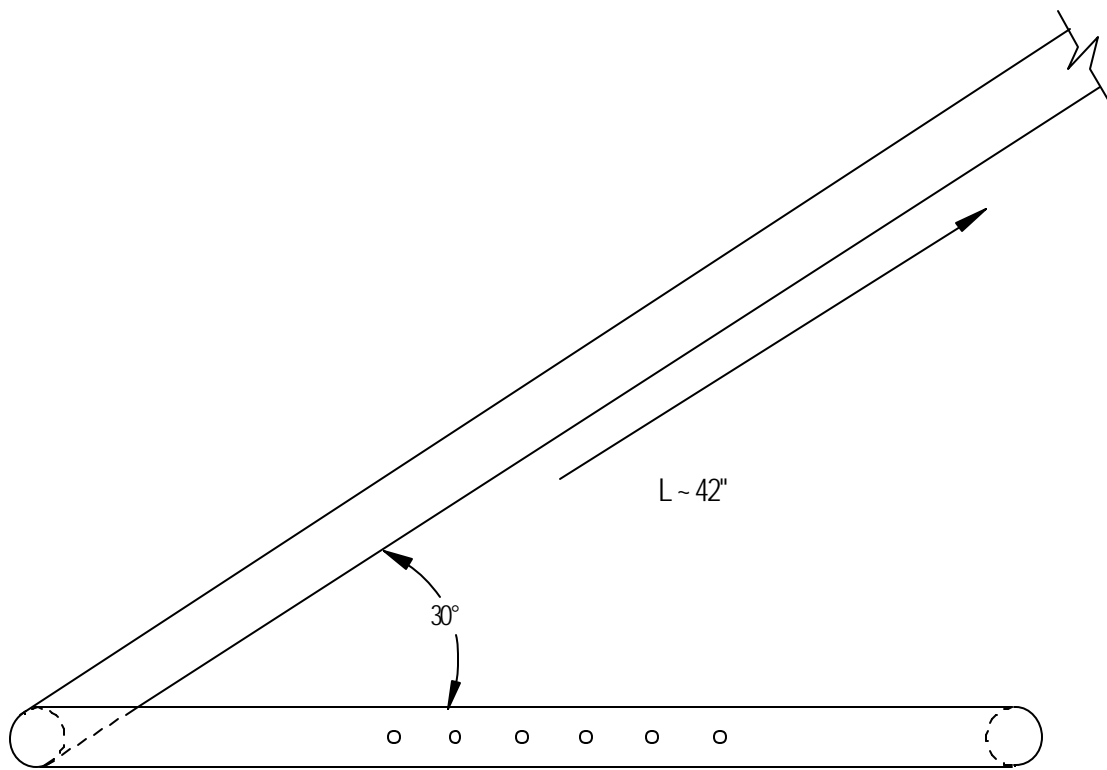

SIDE VIEW OF SQUARE GAS BURNER
FIGURE 12b

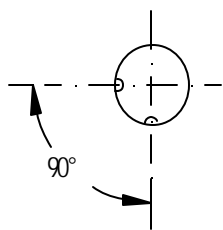

FRONT

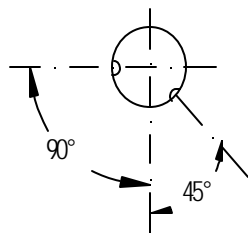

SIDE

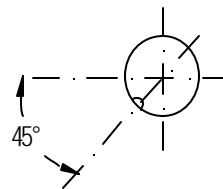

BACK

CROSS SECTIONAL VIEW OF EACH SIDE OF SQUARE GAS BURNER
FIGURE 12c

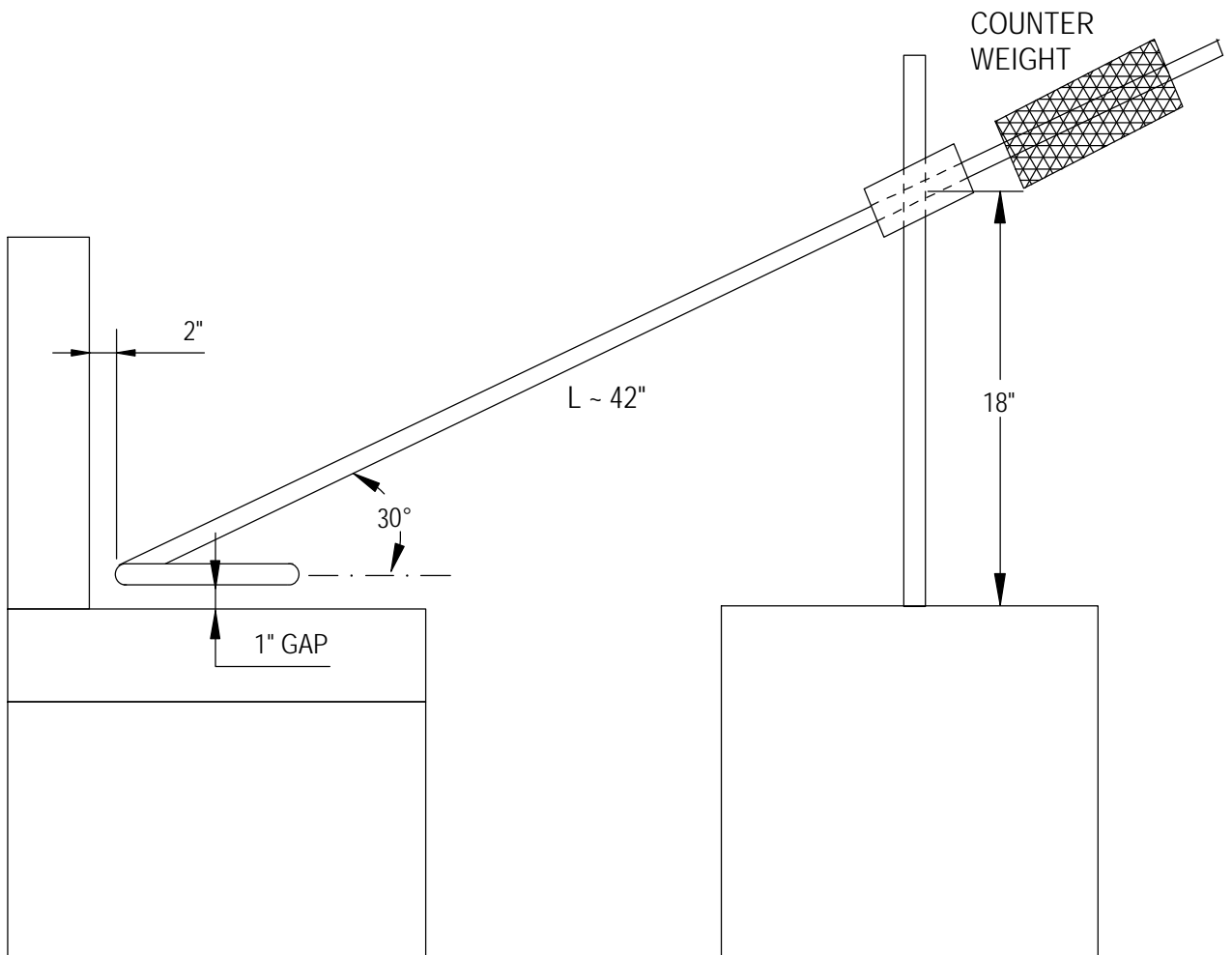

POSITIONING OF SQUARE GAS BURNER ON THE CHAIR
FIGURE 12d

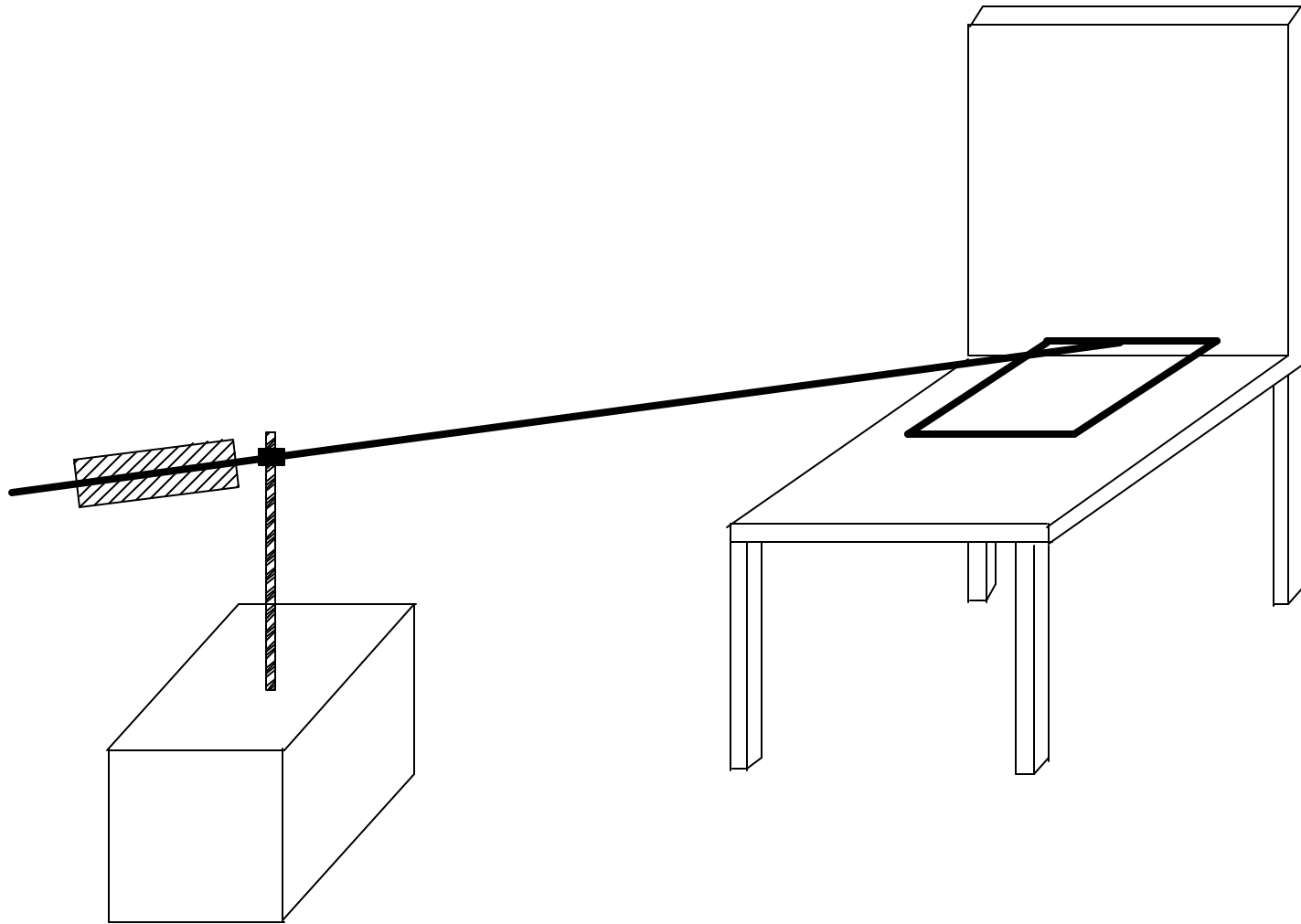

PLACEMENT OF SQUARE GAS BURNER
SEATING FURNITURE NO MORE THAT 40 INCHES ACROSS
FIGURE 13

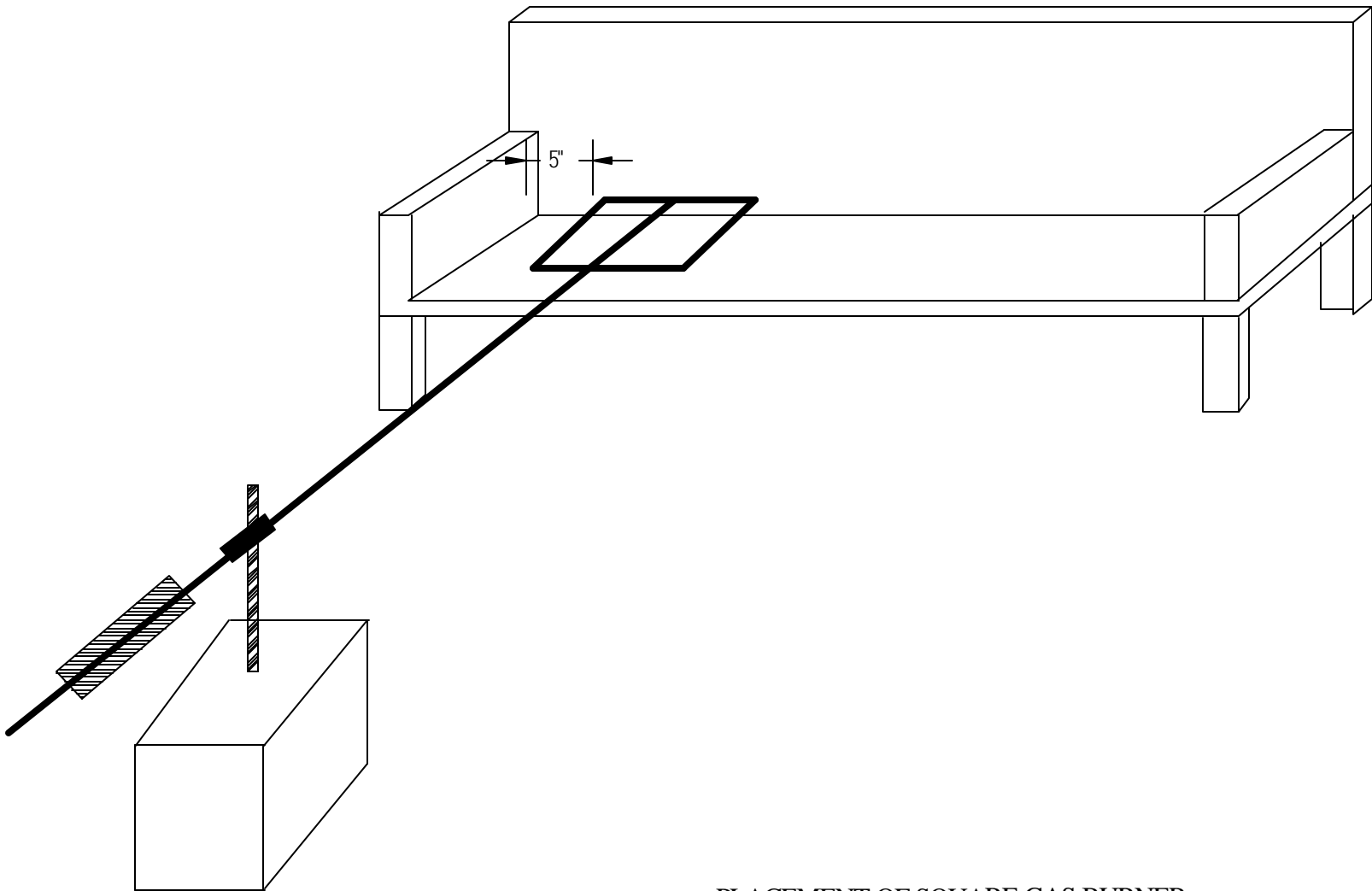

PLACEMENT OF SQUARE GAS BURNER
SEATING ITEMS MORE THAN 40 INCHES ACROSS
FIGURE 14